



**MANUAL – INSTALLATION + SERVICE**

---

**DISPLAY**  
DISIO Series

v400 – Issue Date: 07/07/22

© 2022 Price Industries Limited. All rights reserved.

**PRICE**<sup>®</sup>

# DISPLAY

## TABLE OF CONTENTS

### Product Overview

General .....	1
Features and Layout.....	2

### Installation

Thermostat Installation .....	3
-------------------------------	---

### Applications

Reheat .....	4
Damper - LGB (Linear Gate Bypass) .....	5
Fan Coil (2-pipe and 4-pipe) .....	7

### Display Navigation

Setpoint Adjustment.....	8
LGB Menu Structure.....	9
Fan Coil Menu Structure .....	11
Reheat Menu Structure .....	12

### BACnet Networking

BACnet Wiring .....	13
Termination .....	13
Electrical Noise.....	13
Network Wire Specifications.....	14

### Disio Setup

General .....	15
Download Disio Setup.....	15
Running Disio Setup.....	15

### Maintenance

Hardware Specifications.....	16
------------------------------	----

## SUPPORT ▼

Having difficulty installing this product?  
Price is here to help.

### Application Support

Controls Hotline: 204.654.5613 (Option 4)

Email us at: [support@disio.io](mailto:support@disio.io)

Literature found at: [www.disio.io/display](http://www.disio.io/display)

# DISPLAY

## PRODUCT OVERVIEW

### General

#### DISIO - Display

The Disio Display thermostat is designed to be used as a single thermostat for several applications.

The Disio Display thermostat was designed as a fancoil controller/thermostat solution and can be configured for a number of 2 pipe and 4 pipe fancoil sequences, however due to the number and flexibility of universal inputs and outputs can also be used for pressure dependent terminal unit applications or control of standalone heaters (baseboard, unit heater, or radiant panels).

**The Disio Display thermostat comes equipped with the following features:**

- 7 Segment Display
- Capacitive touch buttons
- Menu button for basic information
- Gesture Presence Sensing
- 24VAC power terminal blocks for power
- [4] Universal Inputs (configurable)
- [4] Universal Outputs (configurable)
- Temperature Sensing
- USB-C port for Service Tool
- (Optional) BACnet MS/TP compatible (terminal blocks)
- Switched HOT/COM Jumper

The Disio Display thermostat can act as a stand-alone thermostat to control any one of the mentioned applications or can connect over BACnet MS/TP to be controlled from a building management system (BMS) when ordered with optional BACnet.

#### DISIO DISPLAY ▼



# DISPLAY

## PRODUCT OVERVIEW

### Features and Layout

#### DISPLAY BACKPLATE ▼

#### VENTILATION (TOP & BOTTOM)

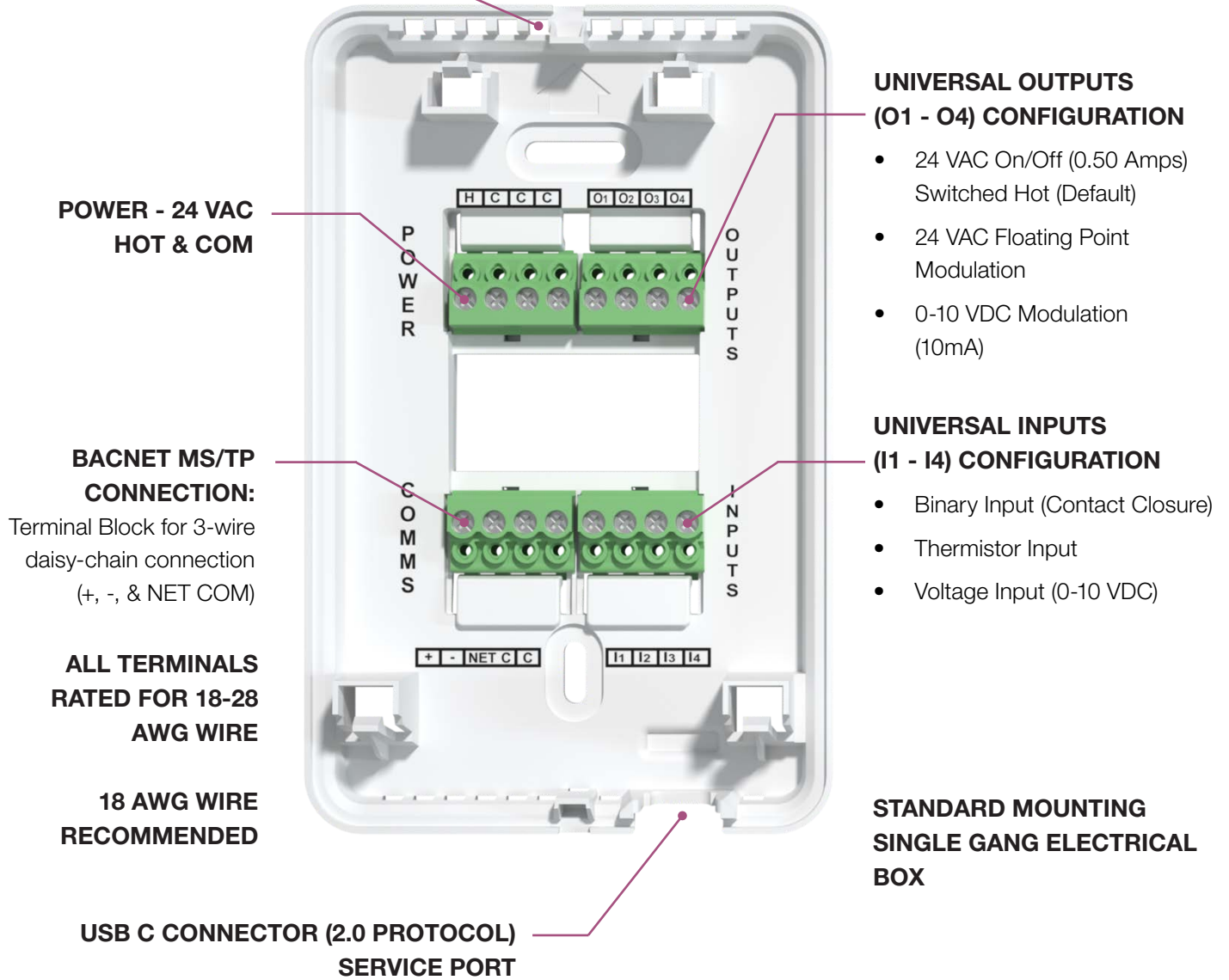

**Switched HOT/COM Jumper:** Disio Display thermostat offers a jumper selectable HOT/COM switch that allows the binary output to be switched HOT or switched COMMON.

**COM Terminals:** All COM terminals on the Disio Display thermostat are internally connected, which allows for a common reference point throughout the board.

**Service Port:** The Disio Display thermostat comes equipped with a USB-C port and cable to plug in and access the Windows based Disio Setup Tool software for configuration of the device on your computer.

# DISPLAY

## INSTALLATION

### Thermostat Installation

#### General Description

The Disio Display thermostat can be installed to any standard single gang electrical box in the vertical orientation to be mounted to drywall or surface using appropriate mounting hardware. The Disio Display thermostat comes as an assembly with two parts; the backing plate which is mounted to the electrical box or to the wall, and the front plate with screen that snaps onto the backing plate by aligning with the pins and the tabs.

#### SURFACE MOUNT DETAIL ▼

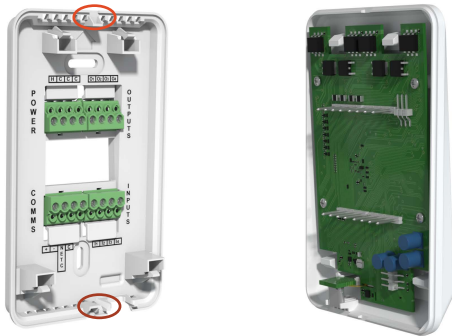

#### Step 1

Separate front screen from backplate by carefully using a small flat screwdriver to pry the bottom of the backplate from the front screen in the pry slot provided. Next pry the top in the same way until separated, then pull apart.

**NOTE:** The first time the screen and backplate are separated, they will be very tight.

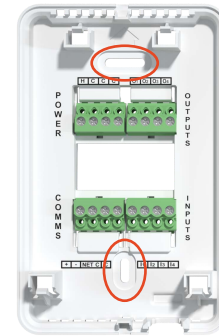

#### Step 2

Pull wires from wall through large hole in backplate, and mount backplate to electrical junction box or to wall by running screws through the slots in the backplate.

**NOTE:** If mounting directly to drywall, drywall anchors must be used to secure the backplate.

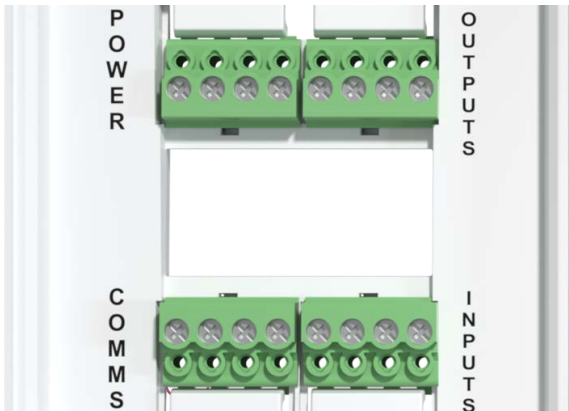

#### Step 3

Strip individual wires used to connect the Disio Display to the device and connect the wires to the terminal blocks. Use the sequence drawing as a guide for connection points to universal inputs/outputs.



#### Step 4

Once the wiring is complete, carefully line up the front face to the backplate and snap back together.

# DISPLAY

## PRODUCT OVERVIEW

### Reheat Applications

The Disio Display thermostat comes pre-programmed to operate any form of reheat in a commercial building, whether it is a baseboard heater, electric duct heater, hot water coil, unit space heater or even a radiant panel.

Configuration of the outputs can be done using the Disio Setup Software software for the Disio Display thermostat.

#### REHEAT APPLICATION ( 0 - 10 VDC, 2 - 10 VDC, 24VAC BINARY, 24VAC TRI-STATE ) ▼

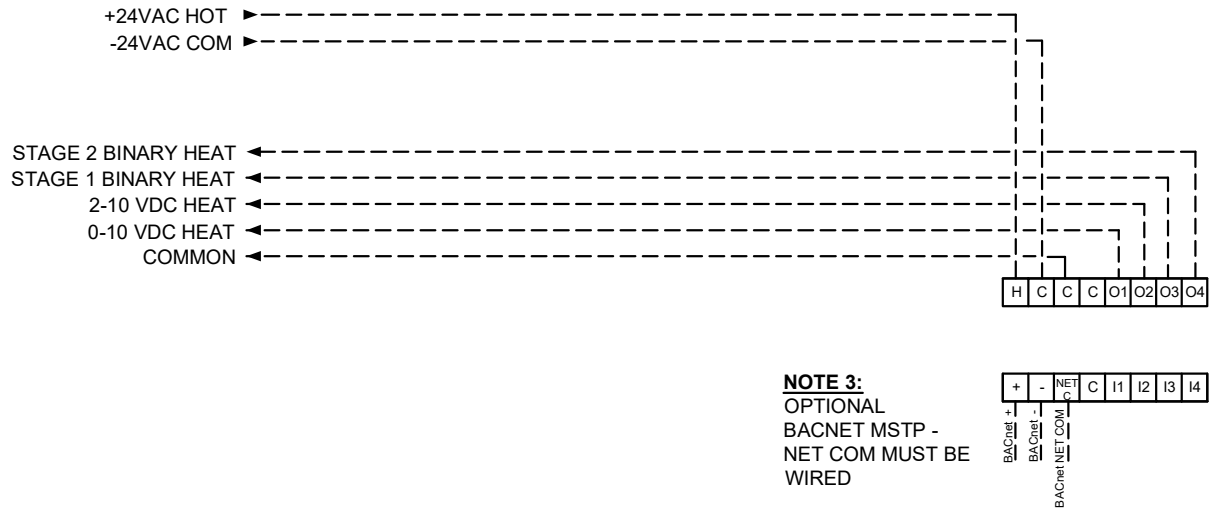

# DISPLAY

## PRODUCT OVERVIEW

### Damper - LGB (Linear Gate Bypass)

The Disio Display thermostat can be pre-programmed to operate as a linear gate bypass box (LGB) application. The LGB unit is a pressure dependent, local bypass terminal unit (often called a dump box) with a tri-state damper actuator. The damper on LGBs operate by sliding along an internal channel which either supplies full design airflow to the space or, at part loads, re-directs some of the air into an open return air plenum. A supply air temperature sensor is provided for heat/cool changeover. With its configurable universal output configuration, binary and modulating reheat control is also available which can be used for duct mounted coils, or to control baseboards, or other external heaters.

#### PRESSURE DEPENDENT, HEAT/COOL CHANGEOVER OR COOLING ONLY WITH BINARY AND ANALOG MODULATING REHEAT ▼

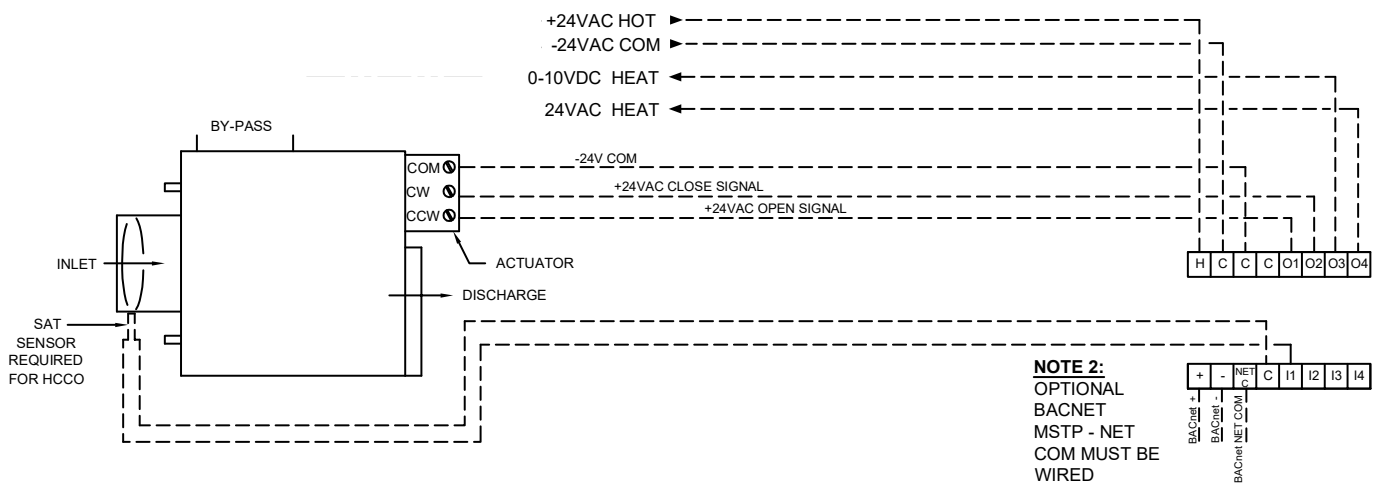

# DISPLAY

## APPLICATIONS

### Fan Coil - 2 Pipe

The Disio Display thermostat can be pre-programmed to operate as a 2-pipe fan coil thermostat from the factory. With its universal output configuration, both on/off and modulating valve sequences are available along with variable ECM fan operation.

For on/off applications, a provided supply pipe temperature sensor is used to detect water temperature for heat/cool changeover.

For modulating applications, an optional discharge air temperature (DAT) sensor can be added in addition to the pipe sensor to modulate the control valve to maintain pre-selected discharge air temperature setpoints for heating and cooling (defaulted to 55 and 90, and configurable through software).

### 2-PIPE ON/OFF HEATING OR COOLING WITH HEAT/COOL CHANGEOVER, VARIABLE SPEED FAN

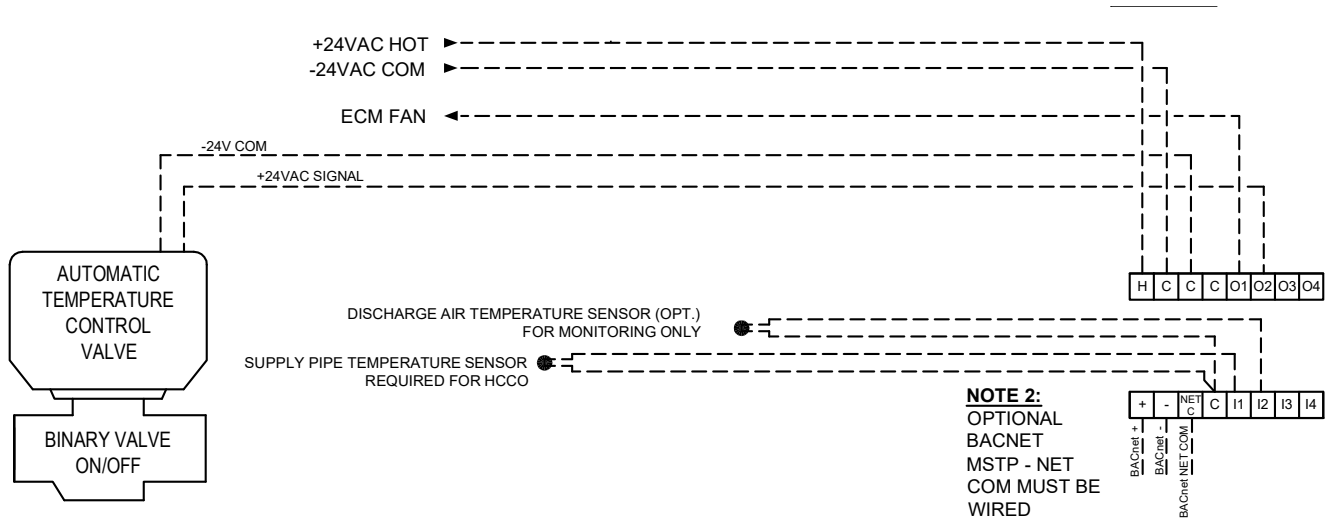

### 2-PIPE MODULATING HEATING OR COOLING WITH DISCHARGE AIR TEMPERATURE CONTROL, VARIABLE SPEED FAN

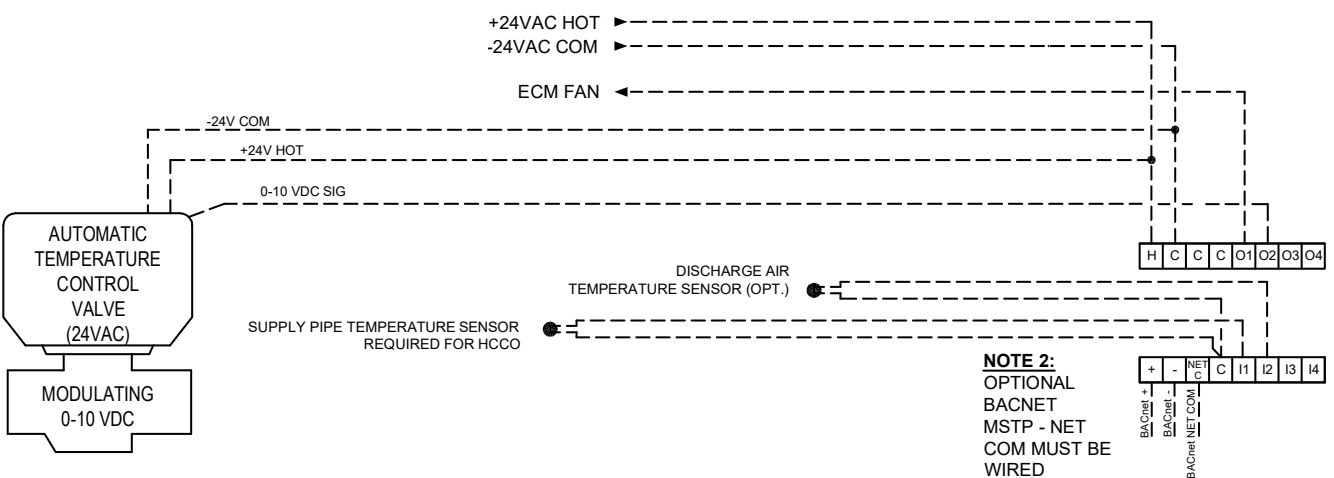



# DISPLAY

## APPLICATIONS

### Fan Coil - 4 Pipe

The Disio Display thermostat can be pre-programmed to operate as a 4-pipe fan coil thermostat from the factory. With its universal output configuration, both on/off and modulating valve sequences are available along with variable ECM fan operation.

For on/off applications, an optional discharge air temperature sensor can be provided for monitoring only.

For applications with one or more modulating valves, an optional discharge air temperature sensor can be provided to modulate the valves to maintain a constant discharge air temperature in heating and/or cooling modes. The discharge air temperature will also be reported over BACnet.

### 4-PIPE ON/OFF HEATING AND COOLING WITH DISCHARGE AIR TEMPERATURE CONTROL, VARIABLE SPEED FAN ▼

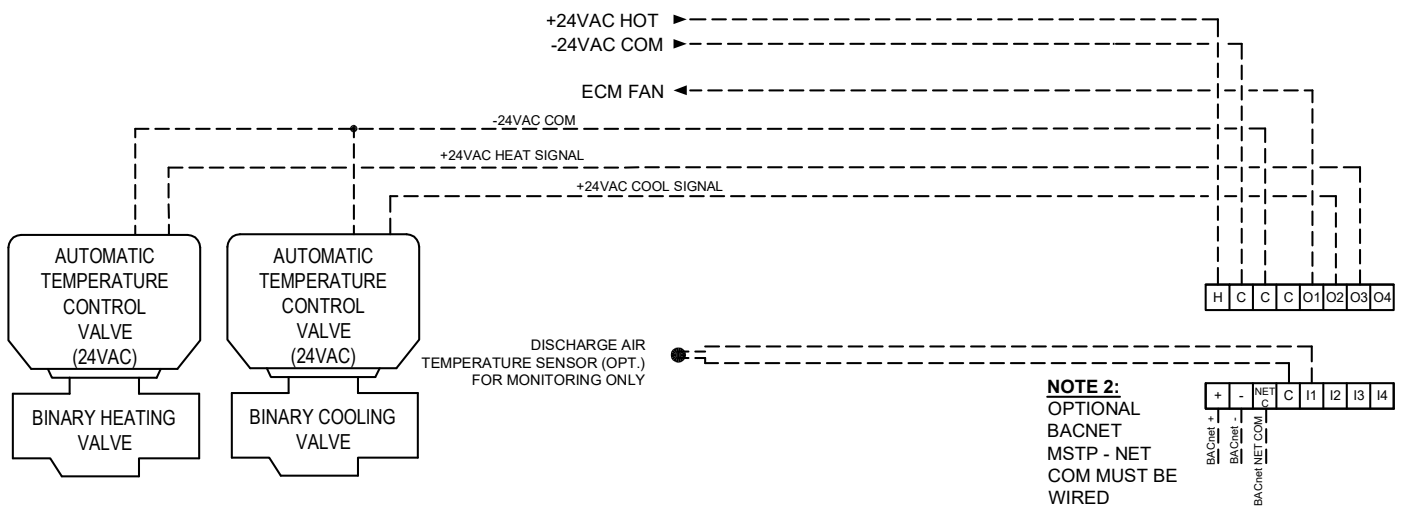

### 4-PIPE MODULATING HEATING AND COOLING WITH OPTIONAL DISCHARGE AIR TEMPERATURE CONTROL, VARIABLE SPEED FAN ▼

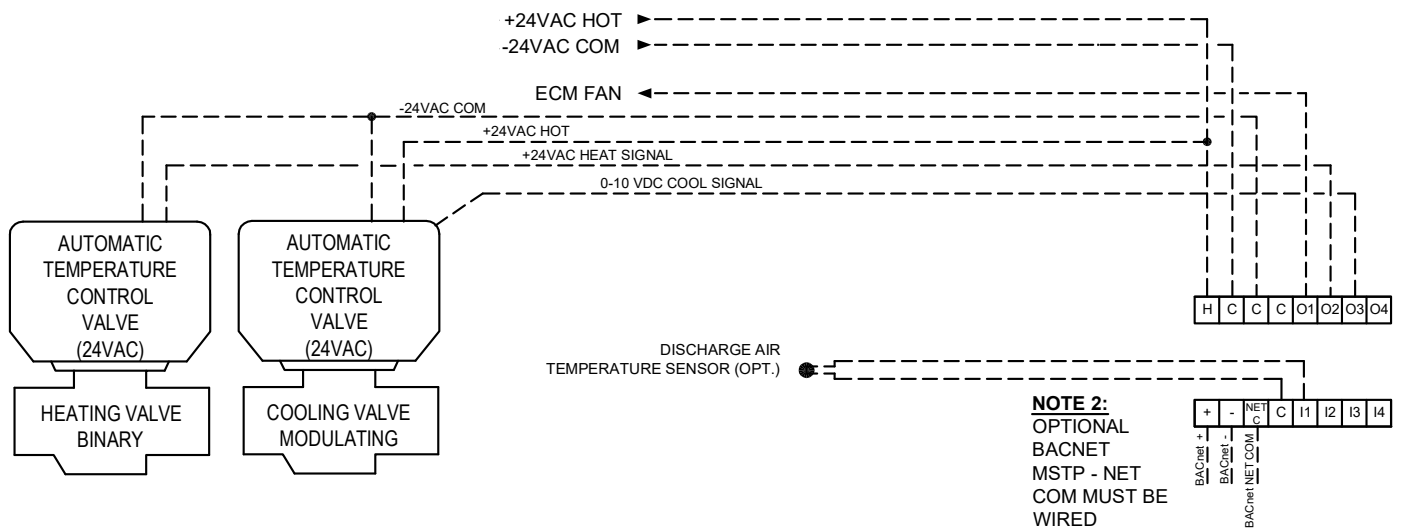

# DISPLAY

## DISPLAY NAVIGATION

### Setpoint Adjustment

Setpoint adjustment with the Disio Display thermostat is easy! Just use the UP arrow button to increase your setpoint and the DOWN arrow button to decrease your setpoint.

The display lights will flash to indicate there is a setpoint adjustment, and then fully illuminate once accepted.

The thermostat will enter the heating proportional band or cooling proportional band when the setpoint is adjusted to +/- 1 Deg C (or 0.5 Deg F) away from the room temperature. This value can be adjusted using the Disio Setup Software and USB-C Cable.

DISIO DISPLAY ▼



# DISPLAY

## DISPLAY NAVIGATION

### Reheat Info Menu

The Menu button displays basic information of the controller regarding application, room temperature, room load, damper position, etc. Values cannot be changed from the menu, just viewed for information only.

Press 'Enter Menu'  button to enter the Info Menu, scroll through using the **up** and **down** buttons.

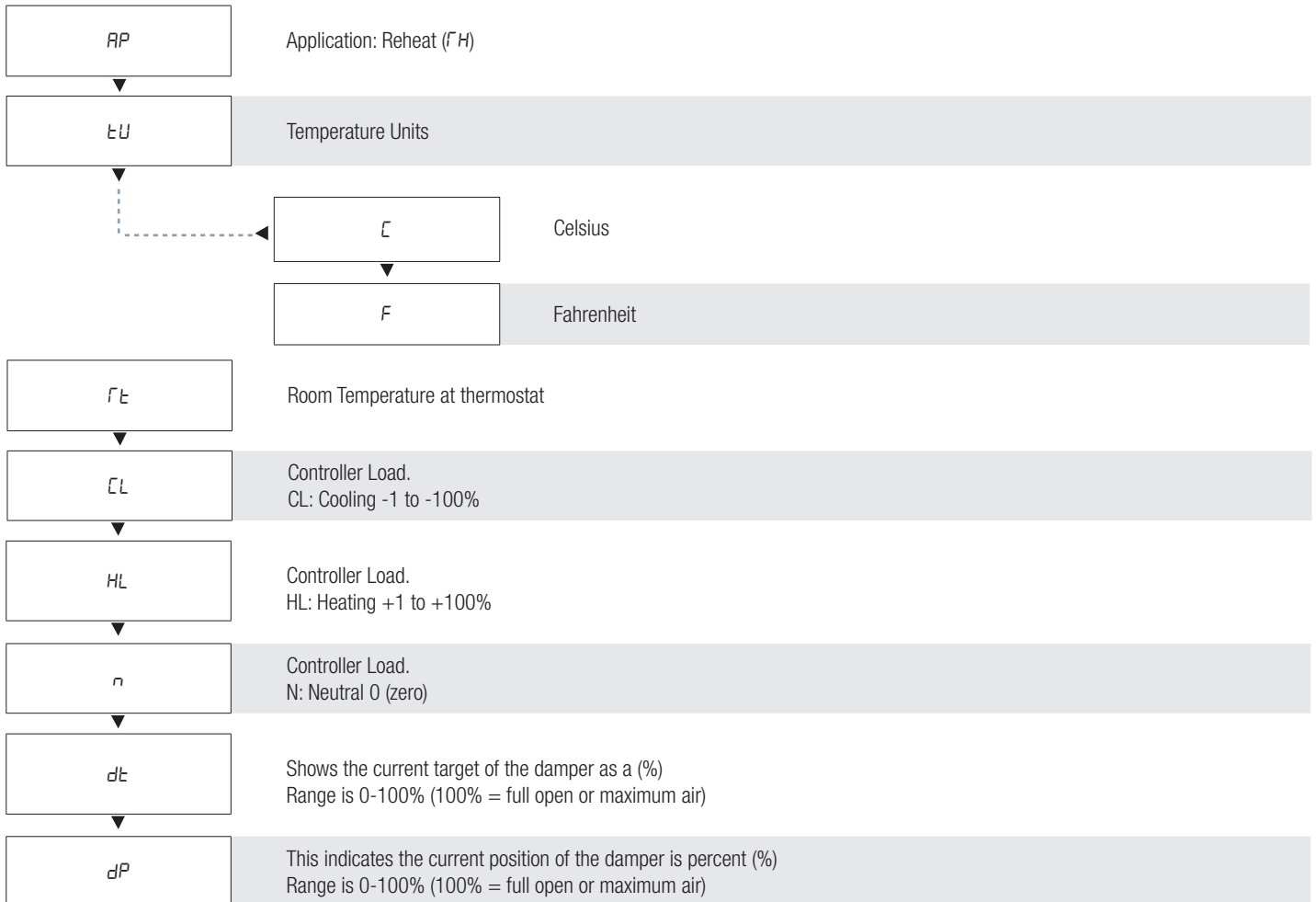

# DISPLAY

## DISPLAY NAVIGATION

### LGB Damper Info Menu

The Menu button displays basic information of the controller regarding application, room temperature, room load, damper position, etc. Values cannot be changed from the menu, just viewed for information only.

Press 'Enter Menu'  button to enter the Info Menu, scroll through using the **up** and **down** buttons.

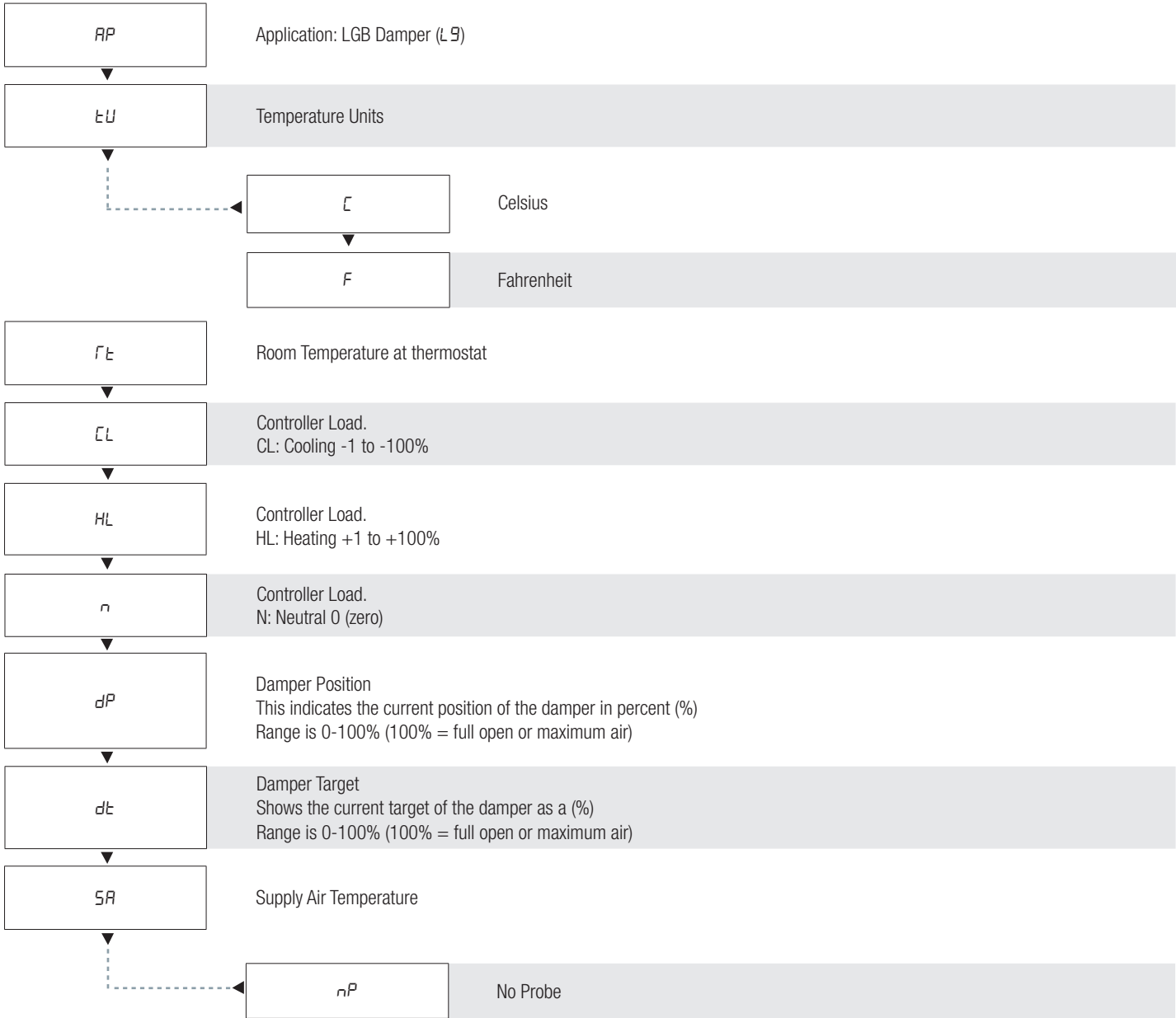

# DISPLAY

## DISPLAY NAVIGATION

### Fan Coil Info Menu

The Info menu shows information about the controller status regarding room load, damper position. No values can be changed from this menu and it is not locked or protected in any way.

Press 'Enter Menu'  button to enter the Info Menu, scroll through using the **up** and **down** buttons.

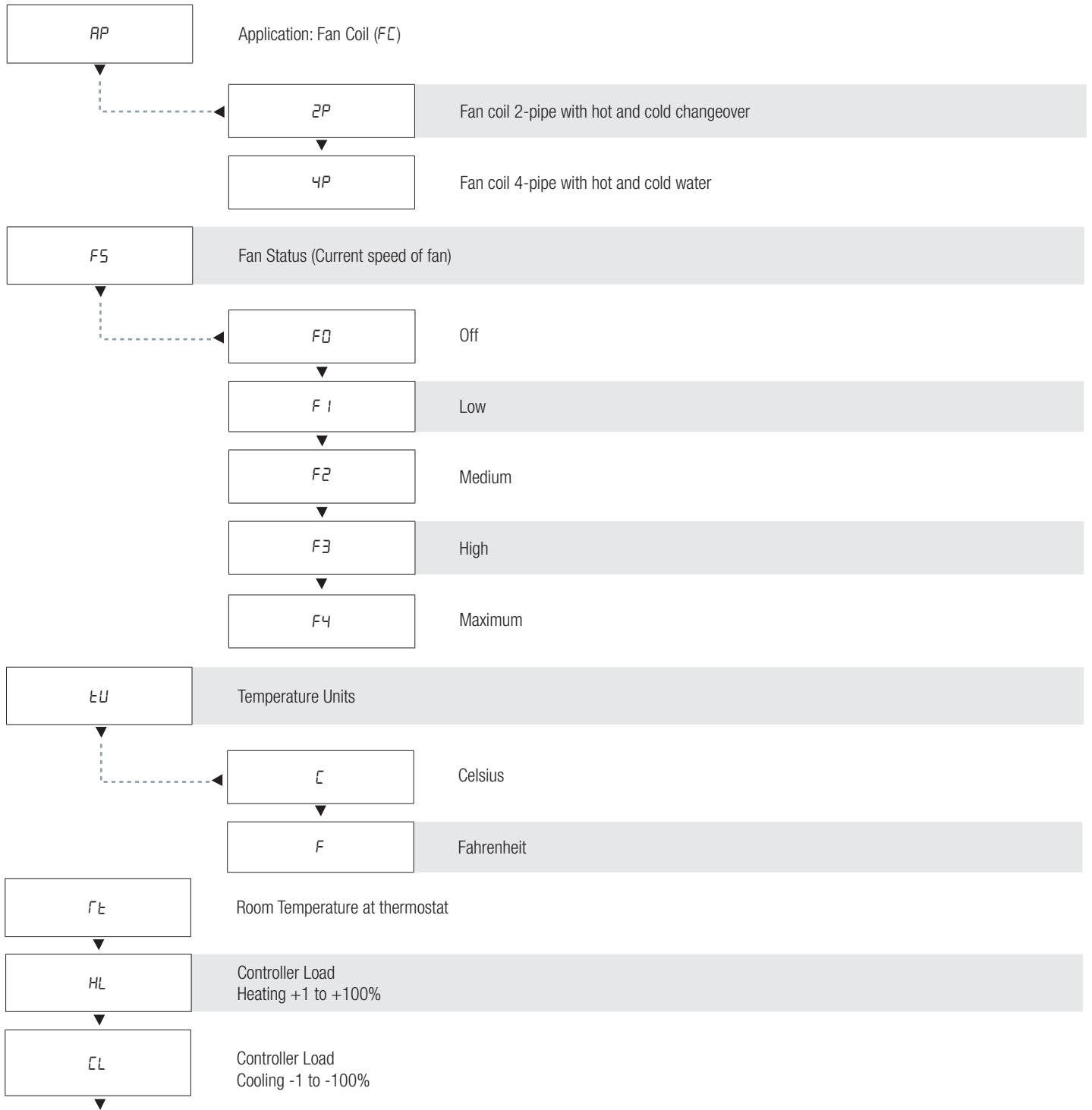

Continue to next page...

# DISPLAY

## DISPLAY NAVIGATION

### Fan Coil Info Menu

The Info menu shows information about the controller status regarding room load, damper position and BACnet Address info. No values can be changed from this menu and it is not locked or protected in any way.

Press 'Enter Menu'  button to enter the Info Menu, scroll through using the **up** and **down** buttons.

Continued from previous page...

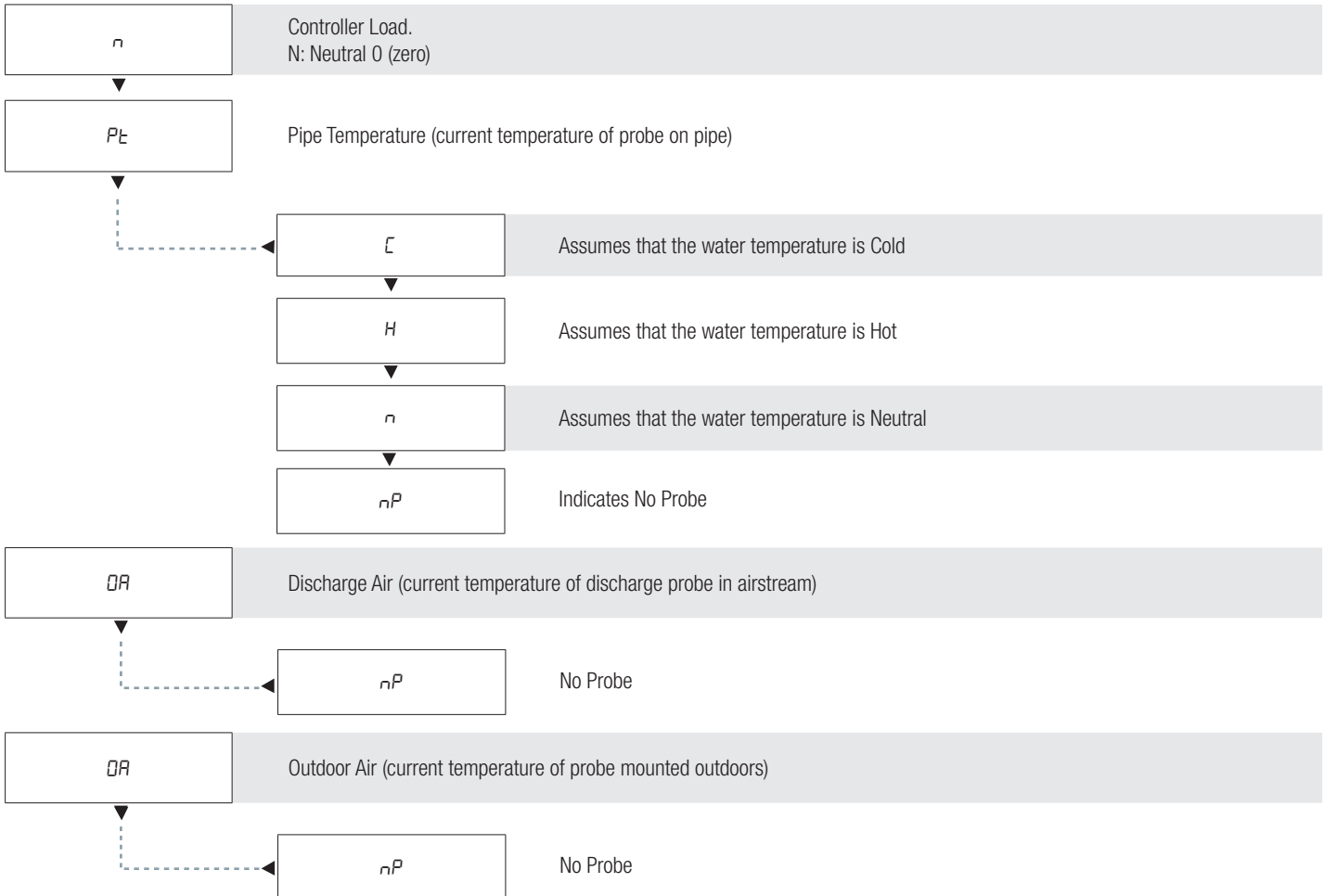

# DISPLAY

## BACNET NETWORKING

### BACnet Wiring

The Disio Display thermostat can be used as a stand-alone thermostat or be integrated into a BACnet MS/TP network using the +, -, and NET COM terminals. Price follows the T568B wiring standard, using the Orange Complement, Orange, Brown, Brown Complement wires for BACnet communication.

BACnet networks must be run in a daisy chain configuration, meaning there is only one main cable and each network device is connected directly along its path, with no more than 30 devices per segment, and MS/TP segment lengths must not exceed 1050 feet.

### Termination

BACnet MS/TP networks must be terminated to ensure proper operation. A network should be terminated twice, once at the beginning and once at the end. Termination helps reduce reflections and noise. The terminating can be done with a 100 ohm resistor across the + and - lines. Most Price controllers have the option for enabling termination by a software menu selection. Turning on termination via software will enable the resistor across the lines.

**Tech Tip:** The Price BACnet MS/TP to IP Router has built in termination and it is enabled by default (since the router is typically the beginning of the entire MS/TP network). Now you only have to go and find/terminate that last device.

### Electrical Noise

Electrical noise can affect both analog signal and digital communications such as BACnet. Therefore do not route high voltage lines next to the BACnet network! Avoid noisy electrical sources such as:

- Variable Frequency Drives
- High current power lines (main panel feeds)
- Fluorescent light fixtures

If you must pass near noisy electrical lines cross at right angles. This will help reduce the amount of noise coupled to the network wires.

#### ELECTRICAL NOISE EXAMPLE ▼

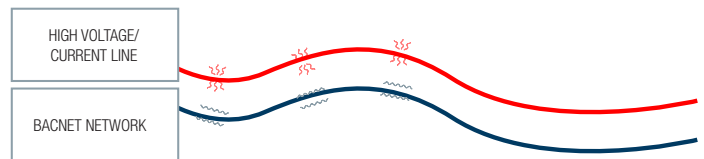

#### BACNET WIRING EXAMPLE ▼

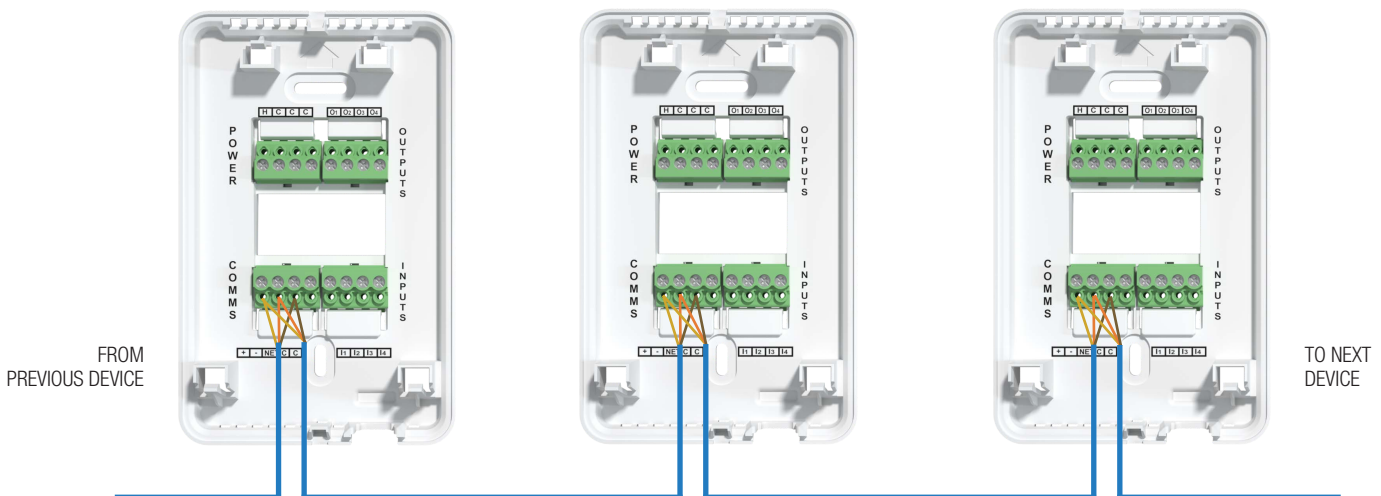

# DISPLAY

## BACNET NETWORKING

### Network Wire Specifications

For the BACnet MS/TP network specific wire is required. Do not use standard power or “thermostat” wire. This wire does not have the necessary requirements for digital communications. While it’s possible it may work (temporarily) the network will be unreliable and not operating at optimal.









#### BACnet MS/TP Wire type recommendations

- Use 1 balanced twisted pair
- Low capacitance (17pF or less)
- Plenum rated (FT6, CMP ratings)
- 100-120 ohm, Balanced
- (CAT5, CAT5E, CAT6 network cable has excellent specifications and will work in almost any BACnet MS/TP application.)
- **Price recommends using the Orange Complement for (+), the Orange for (-), and the Brown and Brown Complement for the (NET COM) connections. These are paired in a standard CAT5E cable.**

**NOTE: NETCOM MUST BE WIRED**



### WIRING ▼

	T568B Color
PIN 1	 white/orange stripe
PIN 2	 orange solid
PIN 3	 white/green stripe
PIN 4	 blue solid
PIN 5	 white/blue stripe
PIN 6	 green solid
PIN 7	 white/brown stripe
PIN 8	 brown solid



# DISPLAY

## DISIO SETUP TOOL

### General

Disio Setup is a FREE Windows based software used to setup and calibrate the Disio Display Thermostat in the field or warehouse. This cutting-edge software connects through a USB to USB-C cable from your Windows computer to the Disio Display Thermostat. Once connected the Disio Setup can scan a device and determine the sequence of operation and display all the parameters that are available inside the controller making setup and troubleshooting quick and easy.

### Downloading Disio Setup Software

To use the Disio Setup software, you must first install the Disio Setup software for Windows computers from the **disio.io** website: [disio.io/setup](https://disio.io/setup) .

#### DISIO SETUP CONNECTION TO COMPUTER



### Running Disio Setup Software

After connecting the USB cable to your computer, click the Disio Setup icon to run the software you previously downloaded from the **disio.io** website.

#### Connection

This column shows the port the controller is connected to, the current firmware, and sequence of operation in the controller. Order information is also available in this column if the controller was calibrated at the factory.

#### Calibration

This tab shows all pre-built sequences of operation available to load into the connected controller. A user can also select their temperature units and update their controller's firmware from this tab.

#### Configuration

This tab shows all the parameters that are available throughout the controller. Some of the variables that can be adjusted in this tab include setpoint limits, (optional) BACnet configurations, etc.

#### DISIO SETUP CONFIGURATION PAGE

Calibration		Configuration			
BAOset Point	Type	No. States	Current Value	Unit	Actions
Output 1	AO		0	Volts	
Output 2	AO		2	Volts	
Room Temperature	AV		57.7	Fahrenheit	<input type="text" value="Value"/> <input type="button" value="Write"/>
Room Temperature Offset	AV		0	Fahrenheit	<input type="text" value="Value"/> <input type="button" value="Write"/>
Room Temperature Setpoint	AV		80	Fahrenheit	<input type="text" value="Value"/> <input type="button" value="Write"/>
Output 3	BO		0	No Units	
Output 4	BO		0	No Units	
Load	AV		100	No Units	
P	AV		1	No Units	<input type="text" value="Value"/> <input type="button" value="Write"/>
I	AV		1	No Units	<input type="text" value="Value"/> <input type="button" value="Write"/>

# DISPLAY

## MAINTENANCE

### Hardware Specifications

<b>Power Requirements</b>	24 VAC Hot (50/60 Hz, 6 VA plus external loads)
<b>Universal/Configurable Outputs (4)</b>	Configurable For: <ul style="list-style-type: none"><li>• 24VAC On/Off (0.50 Amps Max per output) Switched Hot (default)</li><li>• 24 VAC Floating Point Modulation (Damper / Water Valve)</li><li>• 0-10 VDC Modulation, 10mA max per output (Damper / Water Valve / SCR Electric Heat)</li></ul>
<b>Universal/Configurable Inputs (4)</b>	Configurable For <ul style="list-style-type: none"><li>• Binary Input - Contact Closure</li><li>• Thermistor Input (10k Type J), 70° F to 82° F (+/- 1-2° F typical accuracy)</li><li>• Voltage Input (0-10 VDC)</li></ul>
<b>Communication ports</b>	BACnet MS/TP Connection (optional) <ul style="list-style-type: none"><li>• Communication speeds: 9,600, 19,200, 38,400, 76,800 (default)</li><li>• Maximum recommended devices per MS/TP segment: 30 devices</li></ul> USB-C Connection: <ul style="list-style-type: none"><li>• For local setup using Windows based Disio Setup software</li></ul>
<b>Size</b>	3.31" x 1.25" x 5.18"
<b>Weight</b>	.2 lb. (100g)



---

This document contains the most current product information as of this printing.  
For the most up-to-date product information, please go to [priceindustries.com](http://priceindustries.com)

© 2022 Price Industries Limited. All rights reserved.

